

Applications

- Pressure Regulation for Steam Distribution
- Single Point or Multiple Use Applications
- Pressure Control for Steam Plants
- District Heating Systems
- Single Stage Reduction Stations
- Two Stage Reduction Stations
- Parallel Reduction Stations

Iron Horse ED Series Pressure Regulator

**Pressures To 600 PSIG
Temperatures to 750°F**

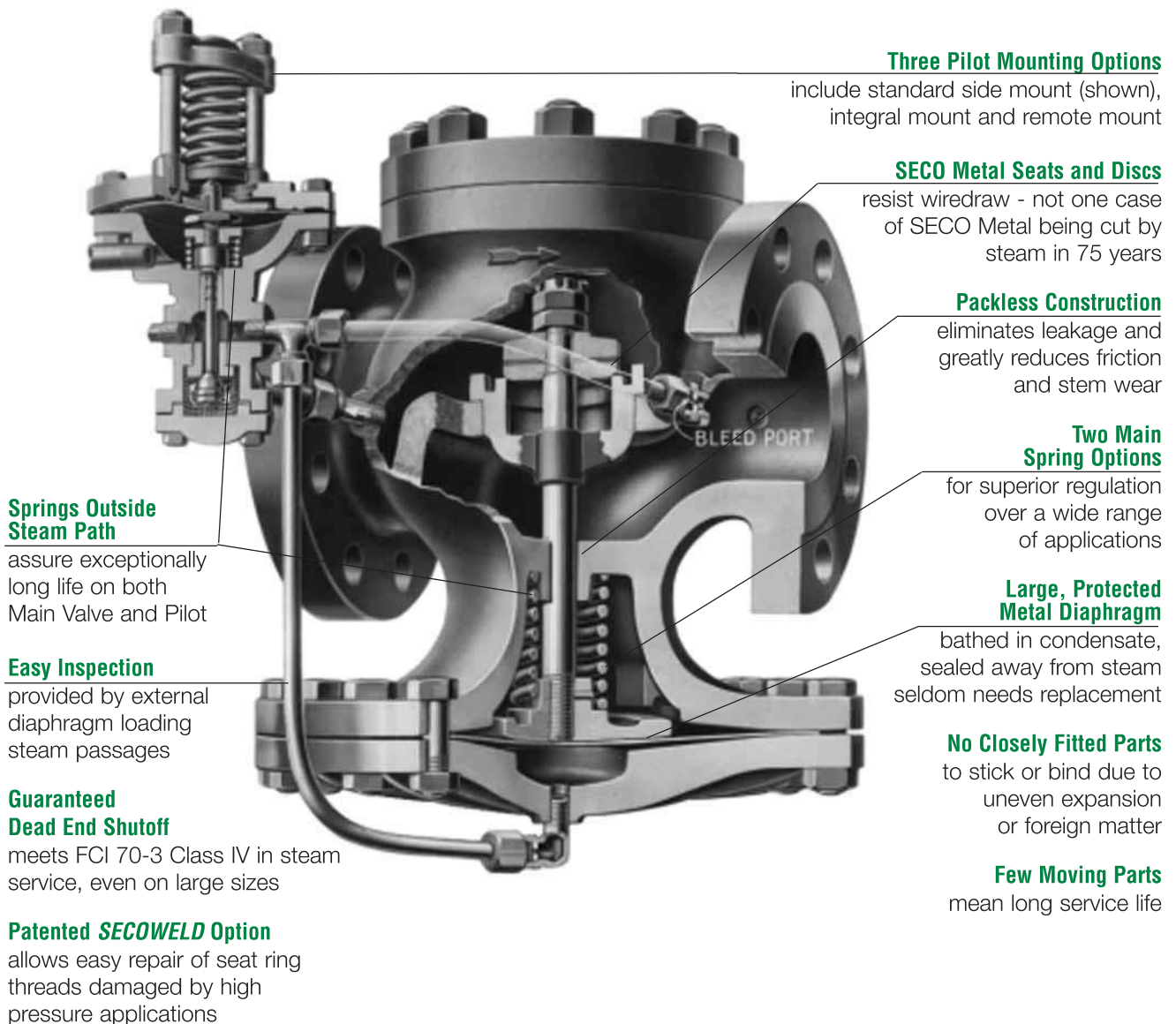

Three Pilot Mounting Options

include standard side mount (shown), integral mount and remote mount

SECO Metal Seats and Discs

resist wiredraw - not one case of SECO Metal being cut by steam in 75 years

Packless Construction

eliminates leakage and greatly reduces friction and stem wear

Two Main Spring Options

for superior regulation over a wide range of applications

Large, Protected Metal Diaphragm

bathed in condensate, sealed away from steam seldom needs replacement

No Closely Fitted Parts

to stick or bind due to uneven expansion or foreign matter

Few Moving Parts

mean long service life

Springs Outside Steam Path

assure exceptionally long life on both Main Valve and Pilot

Easy Inspection

provided by external diaphragm loading steam passages

Guaranteed Dead End Shutoff

meets FCI 70-3 Class IV in steam service, even on large sizes

Patented SECOWELD Option

allows easy repair of seat ring threads damaged by high pressure applications

HOW TO CHOOSE A REGULATOR

If you already know the product that you want information on, find the product page in the Table of Contents. Pages showing popular combinations of Pilot and Regulators are found in the Combination Regulators Chapter. Detailed product information on materials, ratings, dimensions, weights and applications are found in the Products Chapters. All sizing information is contained in the Regulator Sizing Chapter. If you are not sure of what you need, collect all the following information. You will need it to select the right product for your needs.

Inlet Pressure

Flow Rate

Flow Media (i.e.: Steam, Water, etc.)

Desired Delivery Pressure

Noise Restrictions, if any

Type of Pilot Control (i.e.: Self Contained, Pneumatic, Electronic, etc.)

Application (i.e.: Temperature Regulation, Single Stage Pressure Regulation, etc.)

Application data is listed on each Product Page. If you identify the nature of the installation, it will assist you selecting the proper equipment.

DIRECT ACTING OR PILOT OPERATED REGULATOR?

You may be able to use a Direct Operated Regulator for your application. They are generally less expensive than Pilot Operated Regulators. However, they do not provide the same level of accuracy or rangeability. If a Direct Acting Regulator is an option, consult the Direct Operated Valves Chapter to determine which best fits your specific needs. Then, consult the appropriate pages in the Regulator Sizing Chapter to select the exact size you need.

If a Pilot Operated Regulator is required, go to Page 14 (for Pressure Regulators) or Page 15 (for Temperature Regulators). These selection charts will help you to quickly determine the type of product that you need. The Pilot can be self contained, pneumatically or electronically actuated. Consult the appropriate pages in the Regulator Sizing Chapter to select the exact size Regulator and Pilot you need. Overall dimensions of the most popular combinations are provided in the Combination Regulators Chapter.

ECONOMICAL, ENGINEERED OR ENGINEERED WITH NOISE SUPPRESSION?

The choice of how to size a regulator for an application is up to you. The most economical choice does not necessarily take into consideration the optimum loading of the Regulator, which could affect its service life. Properly engineered Spence Regulators have been in continuous service for as much as 50 years. In high pressure reduction stations, noise can be a serious environmental problem. Spence offers a number of Noise Suppression products to reduce this problem. You will find comprehensive noise reduction sizing and selection information in the Noise Reduction Chapter.

THE OPERATING CYCLE OF A SPENCE PRESSURE REGULATOR

The basic Type ED has been selected to illustrate the operation of a SPENCE Pilot Operated Pressure Regulator. This presentation describes the successive steps in the mechanical cycle of the Regulator.

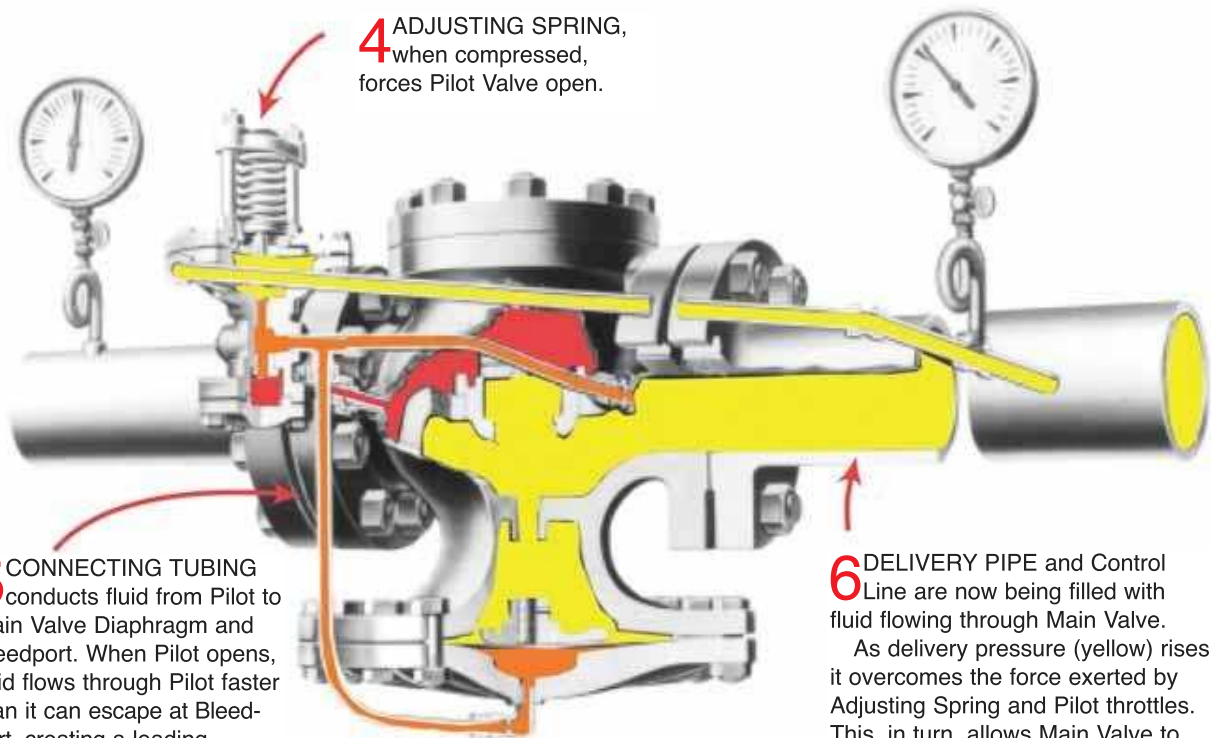
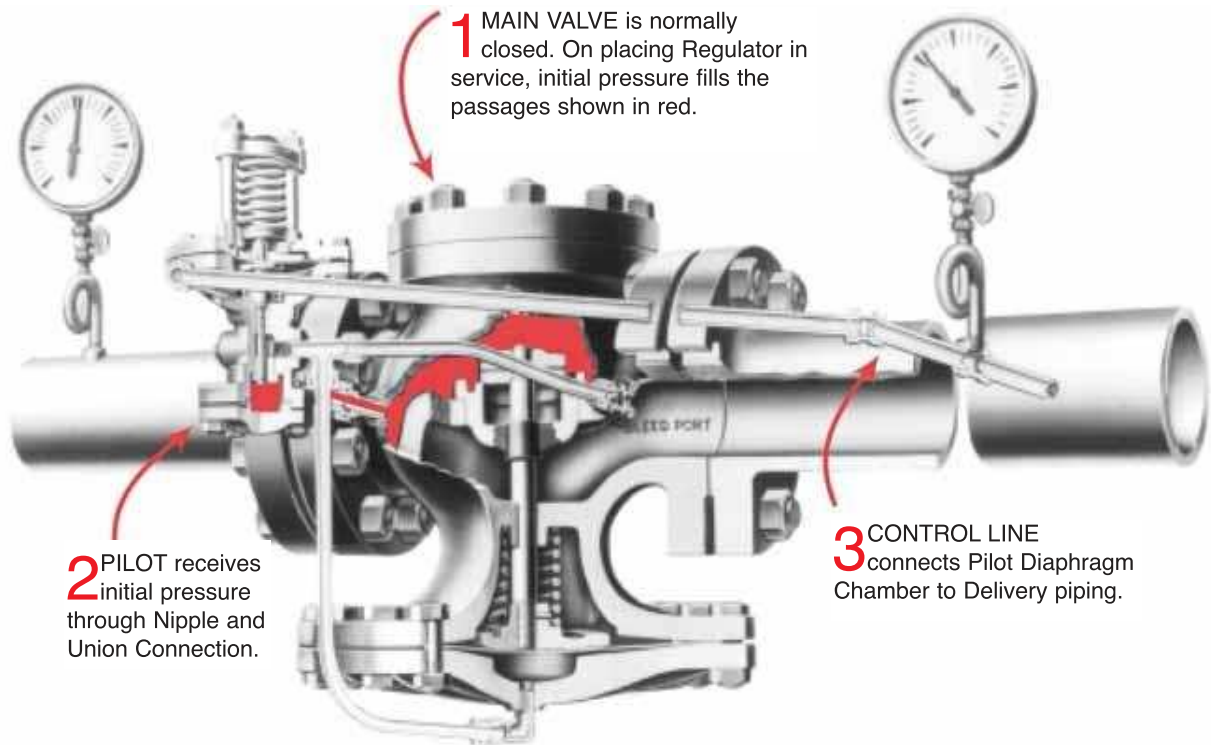

As delivery pressure (yellow) rises, it overcomes the force exerted by Adjusting Spring and Pilot throttles. This, in turn, allows Main Valve to throttle just enough to maintain the set delivery pressure.

If the demand ceases, Pilot closes, allowing the Main Valve to close – effecting a DEAD-END SHUTOFF.

KEY

- HIGH PRESSURE
- MEDIUM PRESSURE
- LOW PRESSURE

THE OPERATING CYCLE OF A SPENCE TEMPERATURE REGULATOR

The Type ET134 has been selected to illustrate the operation of a SPENCE Pilot Operated Temperature Regulator. This presentation describes the successive steps in the mechanical cycle of the Regulator.

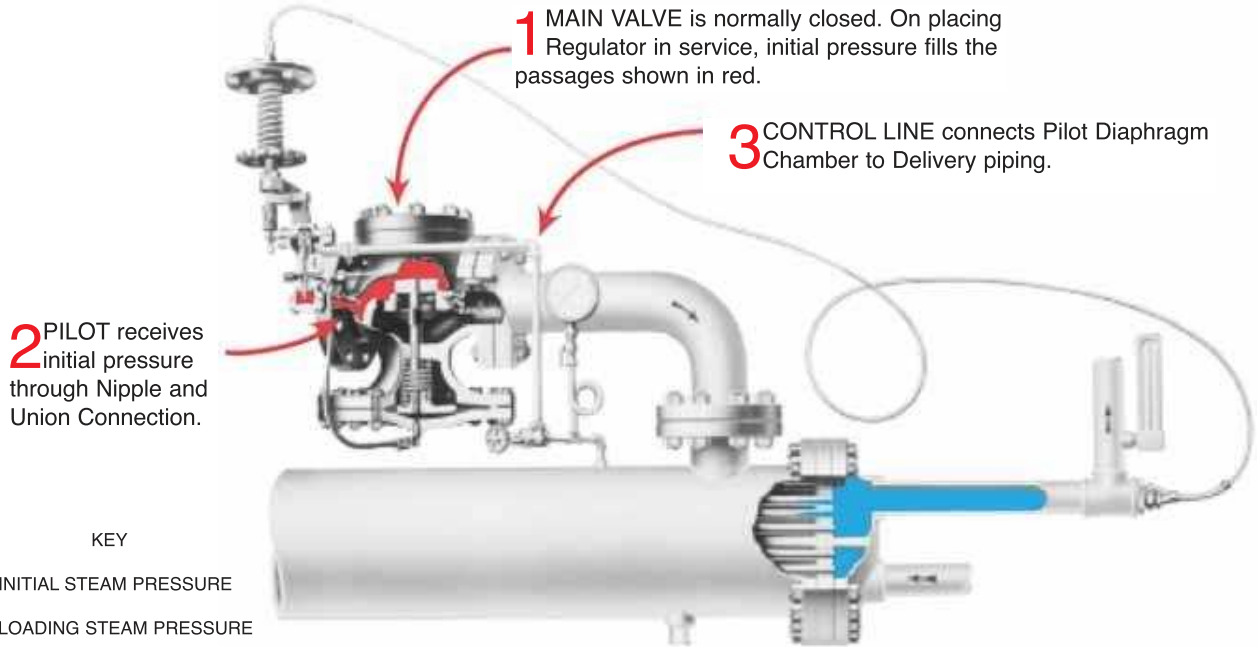

KEY

- INITIAL STEAM PRESSURE
- LOADING STEAM PRESSURE
- DELIVERY STEAM PRESSURE
- VAPOR PRESSURE
- FLUID HEATED

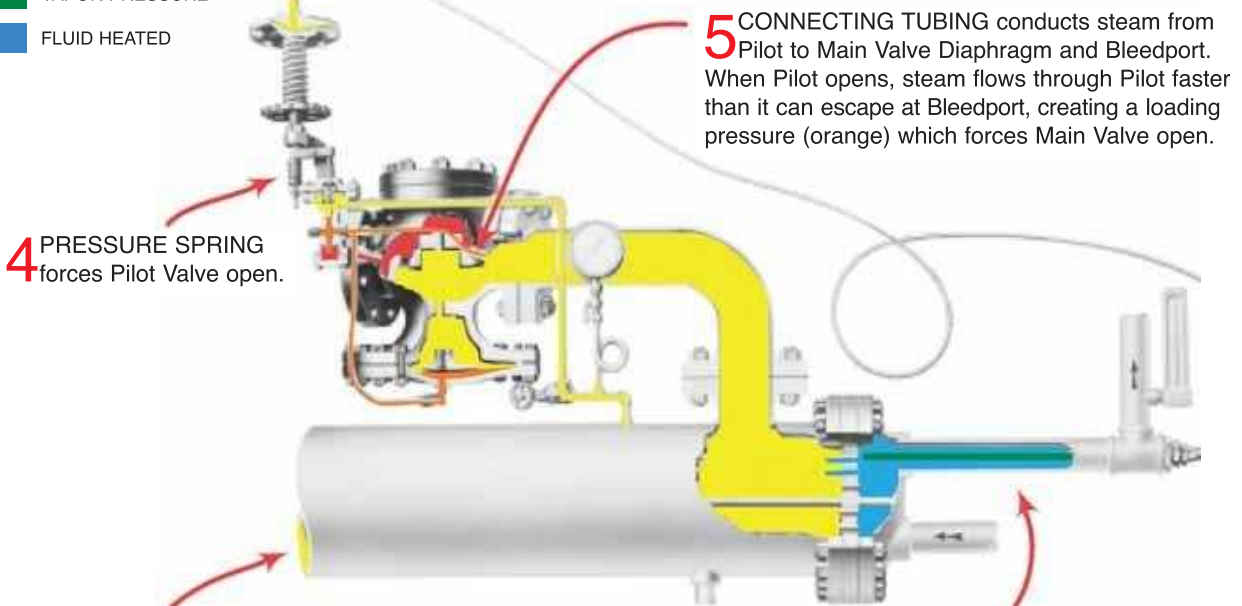

6 HEATER, Delivery Pipe and Control Line are now being filled with steam flowing through Main Valve.

As delivery pressure (yellow) rises, it overcomes the force exerted by Pressure Spring and Pilot throttles. This, in turn allows Main Valve to throttle just enough to maintain the set delivery pressure.

7 THERMOSTAT ELEMENT (vapor tension type) is connected into heater outlet. The rising temperature of the fluid (blue) being heated creates a vapor pressure (green) on the Temperature Diaphragm. When this pressure has reached a point sufficient to overcome the Temperature Adjusting Spring, it applies a force on the Lever so as gradually to decrease the spring loading on the Pressure Diaphragm. This produces a stem-by-step reduction in the delivery pressure as the temperature rises through several degrees.

If the desired temperature is exceeded, the vapor pressure on the Pilot Temperature Diaphragm overcomes the forces of the Spring. This allows Pilot and Main Valve to close tight.

QUICK SELECTION CHART FOR STEAM PRESSURE REGULATORS

Review the application data that you have collected. Consult the chart, starting with the inlet pressure that matches the inlet pressure you have. Next, select your outlet pressure (reduced or delivery pressure). Then select the type of pilot control that you will be using and, finally, the level of accuracy that your system requires. This will lead you to a recommended regulator.

Please bear in mind that these recommendations are general in nature and you should check the Product Pages and Sizing Section to ensure you have selected the correct product. If you need assistance, contact your local Spence Technical Sales Representative.

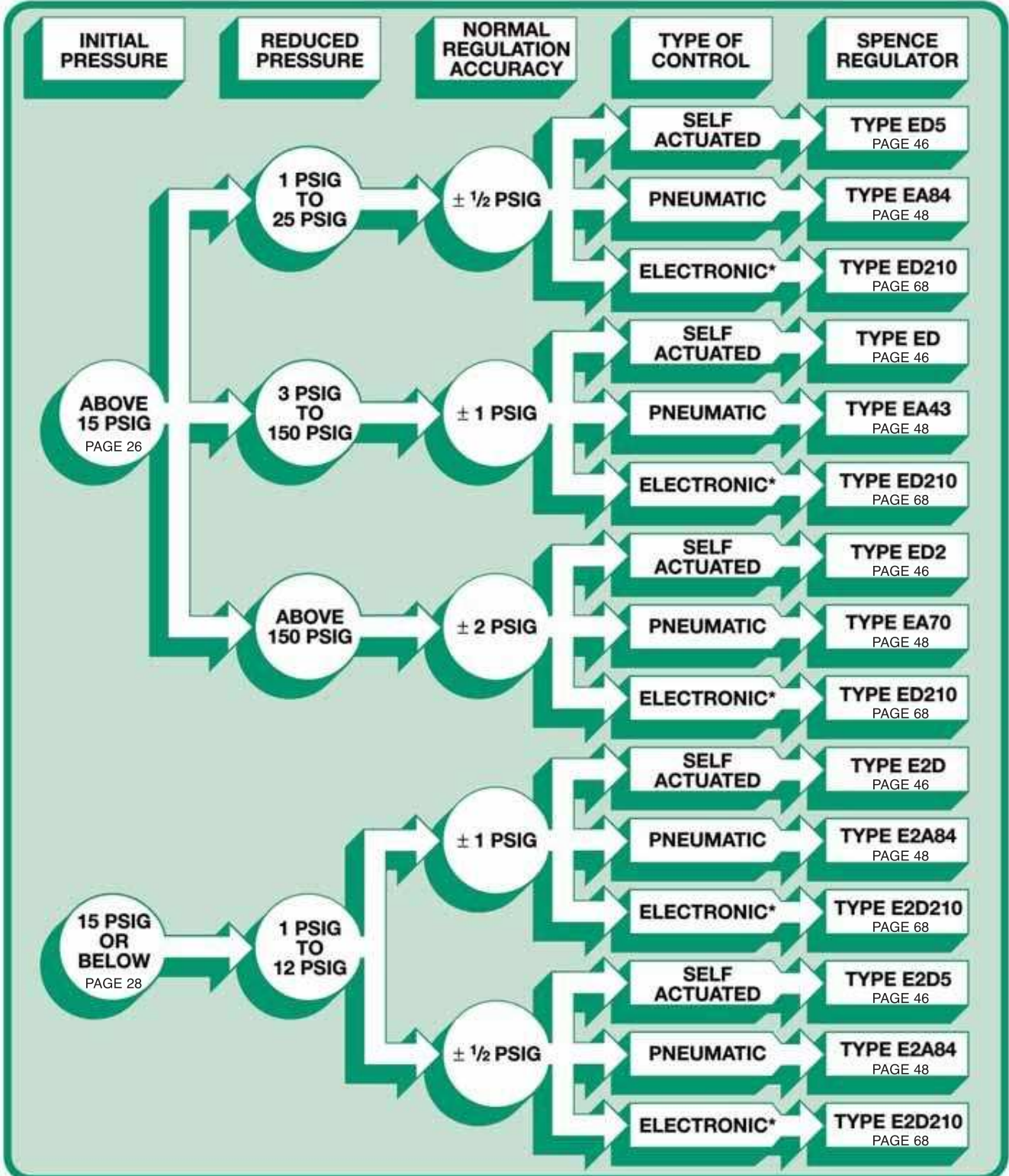

* Electronic Pilot accuracy is a function of controller accuracy.

QUICK SELECTION CHART FOR TEMPERATURE REGULATORS

Review the application data that you have collected. Consult the chart, starting with the inlet pressure that matches the inlet pressure you have. Next, select your outlet pressure (reduced or delivery pressure). Then select the type of pilot control that you will be using and, finally, the level of accuracy that your system requires. This will lead you to a recommended regulator.

Please bear in mind that these recommendations are general in nature and you should check the Product Pages and Sizing Section to ensure you have selected the correct product. If you need assistance, contact your local Spence Technical Sales Representative.

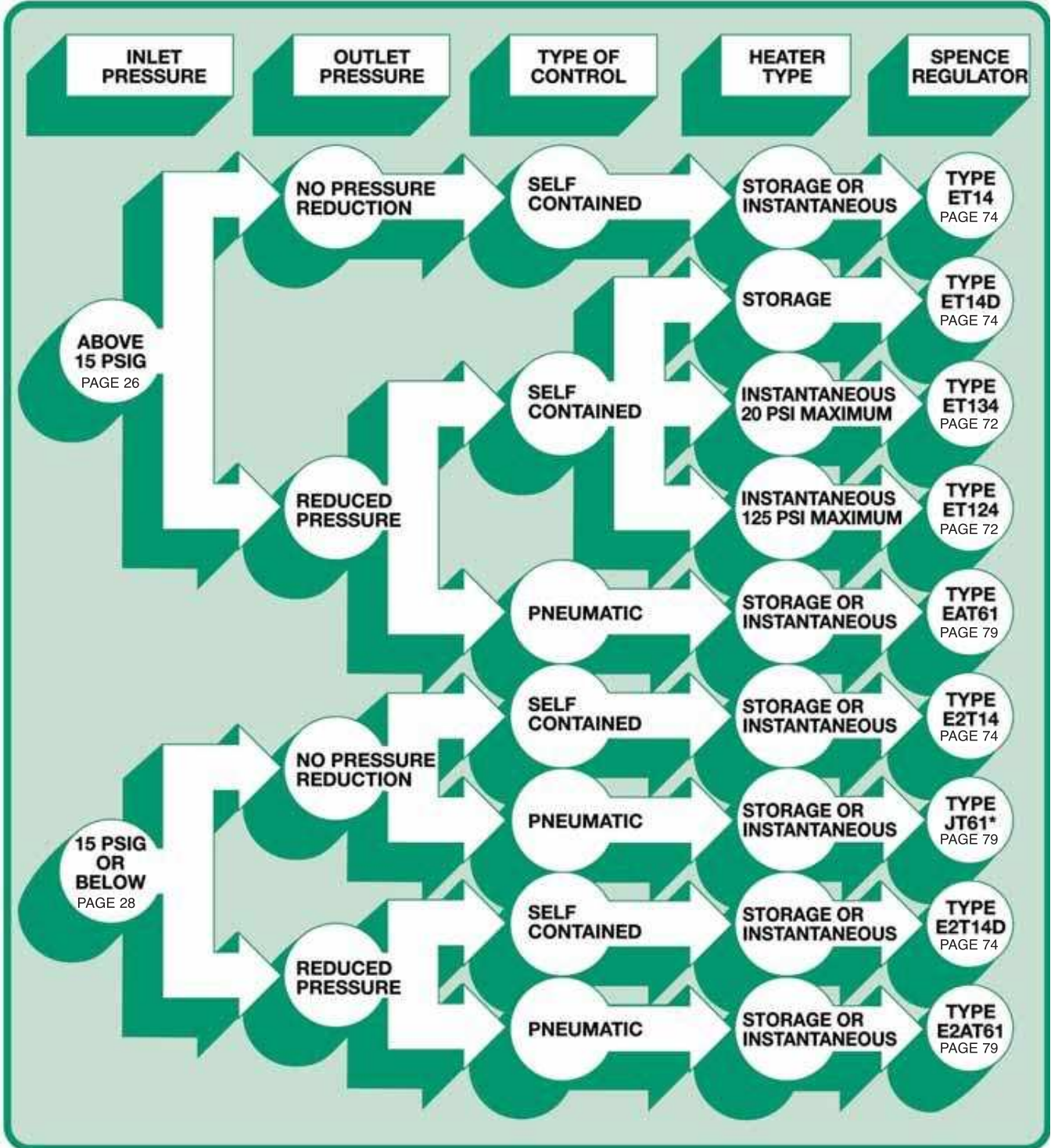

* See Control Valve Section, Page 142

SPENCE MAIN VALVE SPECIFICATION TABLE

TYPES	SIZES, BODY MATERIAL* AND FACINGS										OTHER MATERIALS*					
	CAST IRON		CAST BRONZE		CAST STEEL		Diaphragm	SEAT RINGS		DISCS		Stem	Main Spring			
	Screwed Ends	Flanged ANSI 125	Screwed Ends	Flanged ANSI 250	Screwed Ends 150	Flanged ANSI 300		Flanged ANSI 600	Steam Service	Water, Oil, Air or Gas Service	Steam Service			Water, Oil, Air or Gas Service		
E	SIZES-INCHES															
	Max. Initial Pressure-psi	250	250	250	300	300	600	Stainless Steel	316/420 ^d	316/420	Hycar	Stainless Steel or 17-4PH ^e	Carbon or Inconel ^f			
	Max. Initial Temperature-°F	450	450	450	750	750	750									
Min. Differential ^g -psi ^h	10/30/50	10/30/50	10/30/50	10/30/50	10/30/50	10/30/50	30									
E2	SIZES-INCHES															
	Max. Initial Pressure-psi	15	15	15	15	15	15	Hycar	316	304/420	—	Stainless Steel	Carbon Steel			
	Max. Initial Temperature-°F	250	250	250	250	250	250									
Min. Differential ^g -psi	3	3	3	3	3	3	—									
E5	SIZES-INCHES															
	Max. Initial Pressure-psi	250	250	250	300	300	600	Hycar	316/420	316/420	304/420	Stainless Steel	Carbon Steel			
	Max. Initial Temperature-°F	450	450	450	600	600	600									
Min. Differential ^g -psi	5	5	5	5	5	5	—									
E6	SIZES-INCHES															
	Max. Initial Pressure-psi	250	250	250	250	250	300	Hycar	—	316/420	—	Stainless Steel	Carbon Steel			
	Max. Initial Temperature-°F	200	200	200	200	200	200									
Min. Differential ^g -psi	10	10	10	10	10	10	—									
C34	SIZES-INCHES															
	Max. Initial Pressure-psi	200	165	200	200	200	200	Hycar	—	303/304	—	Stainless Steel	Carbon Steel			
	Max. Initial Temperature-°F	200	200	200	200	200	200									
Min. Differential ^g -psi	10	10	10	10	10	10	—									

^a Main Valves for corrosive fluids or costly gases require special materials.
^b Bronze body and blind flange only.
^c Minimum Differential is the smallest permissible difference between initial pressure (measured at the inlet) and the delivery pressure (measured at the outlet) of the main valve.
^d Secoweld seat construction described in Options Section is regularly furnished for service pressures 400 psi and higher.
^e 17-4 PH stems are furnished for service temperatures exceeding 600°F.
^f Inconel springs are furnished for service pressures exceeding 400 psi and/or temperatures exceeding 600°F.
^g Standard spring (HP) requires minimum 30 PSI differential. 50 PSI is recommended minimum differential. Use optional Low ΔP (LP) main spring for 15 psi minimum differential. 10 psi minimum differential is attainable by adding base bypass and 1/6" bleedport.



MAIN VALVES



TYPE E MAIN VALVE

APPLICATION DATA

- Pressure Regulating for Steam Distribution
- Regulating for Process Control (Temperature or Pressure)
- Maintain Back Pressure or Differential Pressure
- For use with Self-contained, Pneumatic or Electronic Pilots
- Single Point or Multiple Use Applications
- Slow Start-up or Shutdown

SIZING INFO
PAGE 106

VALVE RATINGS

Valve Ends ASME/ANSI	Pressure PSIG (bar)	Temperature °F (°C)
-------------------------	------------------------	------------------------

CAST IRON

B16.4 Class 250 NPT	250 (17.2)	@ 450 (232)
B16.1 Class 125 Flanged	125 (8.6)	@ 450 (232)
B16.1 Class 250 Flanged	250 (17.2)	@ 450 (232)

CAST STEEL

B16.34 Class 300 NPT	300 (21.0)	@ 600 (315)†
B16.34 Class 150 Flanged	150 (10.3)	@ 500 (260)
B16.34 Class 300 Flanged	300 (21.0)	@ 600 (315)†
B16.34 Class 600 Flanged	600 (41.4)	@ 600 (315)†

†750°F (400°C) construction available on request.
Other pressure/temperature ratings available; consult factory.
Maximum downstream pressure is 300 psi.

Canadian Registration # OC 0591.9C

Installation Tip: Add EZ Connections for ease of maintenance
SEE PAGE 40

TYPE E MAIN VALVE

SIZES 3/8" – 12"
PRESSURES to 600 PSIG at 750°F

- Normally Closed
- Single Seat
- Balanced Metal Diaphragms
- Protected Main Spring
- Fluid, Gas & Vapor Applications
- Multiple Trims for Precise Sizing
- ANSI/FCI 70-2 Class IV Shutoff
- FCI 70-3 Class VI Shutoff
- Virtually Frictionless for Long Service Life
- Packless Construction
- Easy In-line Maintenance
- Wide Variety of Pilots for Many Applications
- Minimum Operating ΔP 10 psi (.7 bar)
- Lifetime Warranty against Wiredrawing of Seat & Disc*

OPTIONS (SEE PAGE 42)

- Composition Disc
- Parabolic Disc
- Balanced Construction
- Integral Mount Pilot
- Insulcap Insulating Jacket
- Secoweld
- High Temperature Construction
- Dashpot
- Low ΔP (LP) Main Spring
- EZ Connections

TYPICAL CONFIGURATIONS

- PRESSURE REDUCINGTYPE ED SERIES
- AIR ADJUSTEDTYPE EA SERIES
- BACK PRESSURETYPE EQ SERIES
- PUMP GOVERNORTYPE EP SERIES
- LOAD ALLOCATINGTYPE EFD
- AIR CONTROLLEDTYPE EAP60
- ELECTRONIC SLOW STARTTYPE ED208D
- SOLENOID CONTROLLEDTYPE EMD
- SOLENOID ACTUATEDTYPE EM
- DIFFERENTIALTYPE EN
- TEMPERATURE CONTROLTYPE ET SERIES

RATED FLOW COEFFICIENTS (Cv)

SEAT FACTOR	REGULATOR SIZE														
	3/8	1/2	3/4	1	1 1/4	1 1/2	2	2 1/2	3	4	5	6	8	10	12
Full	1.5	2.8	5.4	8.8	14.1	19.8	31	44	74	109	169	248	444	706	1113
Full 75 %	—	2.2	4.2	7.2	11.1	15.9	22.9	37	56	88	136	188	353	558	880
Full 50 %	—	1.7	2.6	6.3	7.4	11.3	17.7	25	42	65	94	139	252	400	631
Normal	.66	1.55	4.8	7.5	10.4	14.6	17.6	24	43	78	115	151	249	377	631
Normal 75 %	—	—	—	—	—	—	—	18	34	62	89	110	187	294	463
Normal 50 %	—	—	—	—	—	—	—	14	26	46	65	83	139	230	363

* When installed according to factory specifications.

TYPE E MAIN VALVE

SPECIFICATION

The valve shall be self-operated, external pilot type, single seated, metal diaphragm actuated, normally closed design. The valve will function quickly and shut tight on dead end service. Internal parts including seats, discs, stems and diaphragms shall be of stainless steel. There shall be no springs in the steam space and no stuffing box. The valve shall be easy to maintain with all parts accessible without removal from the line.

MATERIALS OF CONSTRUCTION

Body, Cast IronASTM A126 Cl. B
 Body, Cast SteelASTM A216 WCB
 Stem303 St. Stl. ASTM A582
 Disc 3/4 - 5"420 St. Stl. ASTM A743 CA-40
 Disc 6 - 12"304 St. Stl. ASTM A167/A240
 Seat 3/4 - 5"420 St. Stl. ASTM A743 CA-40
 Seat 6 - 12"316 St. Stl. ASTM A743-79 CF-8M
 GasketNon-asbestos
 DiaphragmStainless Steel MIL-S-5059C
 SpringSteel

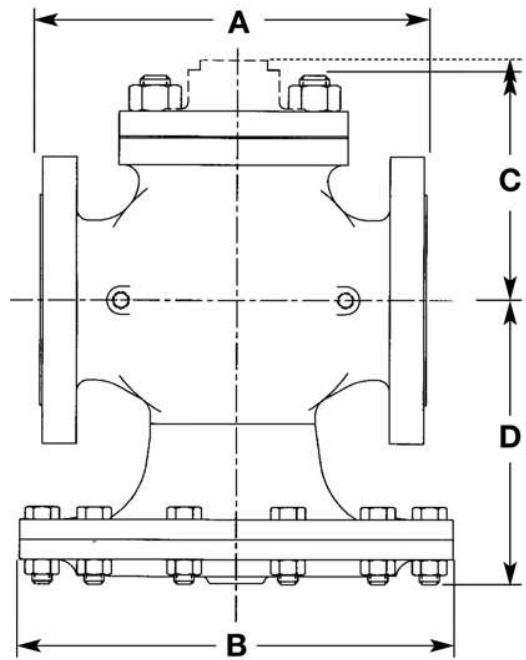

TYPE E
MAIN VALVE

TYPE E MAIN VALVE

FITTINGS ON
PAGE 44

DIMENSIONS inches (mm) AND WEIGHTS pounds (kg)

SIZE	FACE TO FACE DIMENSIONS					B	C				D*	APPROX. WT.				
	A						Std. Mount	Integral Mount				ANSI NPT	ANSI 125,150	ANSI 250,300	ANSI 600	
	ANSI NPT	ANSI 125,150	ANSI 250	ANSI 300	ANSI 600			ANSI 600	Cl & Brz.	Steel						Steel 600
3/8 (10)	4 3/8 (111)	—	—	—	—	5 7/8 (149)	2 3/4 (70)	—	3 1/2 (89)	3 1/2 (89)	—	5 1/4 (133)	14 (6)	—	—	—
1/2 (12)	4 3/8 (111)	—	—	—	6 (152)	5 7/8 (149)	2 3/4 (70)	2 3/4 (70)	3 1/2 (89)	3 1/2 (89)	3 5/8 (92)	5 1/4 (133)	14 (6)	—	—	20 (9.1)
3/4 (19)	4 3/4 (111)	—	—	—	6 3/8 (162)	6 1/2 (165)	2 7/8 (73)	3 7/8 (98)	3 3/8 (92)	3 3/4 (95)	4 1/2 (114)	5 1/2 (140)	18 (8)	—	—	28 (13)
1 (25)	5 3/8 (137)	5 1/2 (140)	6 (152)	6 1/2 (165)	6 1/2 (165)	7 (178)	3 5/8 (92)	4 1/4 (108)	4 3/8 (111)	4 3/8 (111)	4 3/4 (121)	6 1/4 (159)	23 (10)	26 (12)	31 (14)	32 (15)
1 1/4 (32)	6 1/2 (165)	6 3/4 (171)	7 1/4 (184)	7 7/8 (200)	7 7/8 (200)	7 7/8 (200)	4 1/8 (105)	4 5/8 (117)	4 (102)	4 5/8 (117)	5 (127)	6 1/2 (165)	33 (15)	37 (17)	41 (19)	45 (20)
1 1/2 (38)	7 1/4 (184)	6 7/8 (175)	7 3/8 (187)	8 (203)	8 (203)	8 3/4 (222)	4 3/8 (111)	5 1/8 (130)	4 3/8 (111)	5 (127)	—	7 1/8 (181)	43 (20)	47 (21)	55 (25)	58 (26)
2 (51)	7 1/2 (191)	8 1/2 (216)	9 (229)	10 1/4 (260)	10 1/4 (260)	9 7/8 (251)	5 1/4 (133)	5 3/4 (146)	5 (127)	5 5/8 (143)	5 3/4 (146)	7 5/8 (194)	62 (28)	73 (33)	78 (35)	83 (38)
2 1/2 (64)	—	9 3/8 (238)	10 (254)	11 1/4 (286)	11 1/4 (286)	10 7/8 (276)	5 3/4 (146)	7 7/8 (200)	5 1/2 (140)	6 (152)	8 1/4 (210)	8 3/8 (213)	—	95 (43)	100 (45)	130 (59)
3 (76)	—	10 (254)	10 3/4 (273)	12 1/4 (311)	12 1/4 (311)	11 3/4 (298)	6 5/8 (168)	9 1/8 (232)	6 3/8 (162)	7 1/8 (181)	—	9 1/4 (235)	—	125 (57)	140 (64)	175 (80)
4 (102)	—	11 7/8 (302)	12 1/2 (318)	12 1/2 (318)	14 1/2 (368)	14 3/4 (375)	7 5/8 (194)	10 5/8 (270)	7 1/4 (184)	8 (203)	—	11 7/8 (302)	—	210 (95)	230 (105)	310 (141)
5 (127)	—	13 5/8 (346)	14 1/2 (368)	14 1/2 (368)	16 1/2 (419)	16 7/8 (429)	8 1/2 (216)	12 1/2 (318)	8 1/8 (206)	8 1/2 (216)	—	12 1/2 (318)	—	295 (134)	310 (141)	490 (223)
6 (152)	—	15 1/8 (384)	16 (406)	16 (406)	17 3/8 (441)	19 3/4 (502)	10 (254)	13 3/4 (349)	9 1/2 (241)	9 1/2 (241)	13 3/8 (346)	14 1/8 (359)	—	420 (191)	470 (214)	655 (298)
8 (203)	—	19 (483)	20 (508)	20 (508)	21 5/8 (549)	22 1/2 (572)	11 1/2 (292)	15 3/8 (391)	11 1/4 (286)	11 3/4 (298)	—	17 1/4 (438)	—	700 (318)	710 (323)	1070 (486)
10 (254)	—	23 5/8 (600)	25 (635)	25 (635)	—	28 (711)	13 3/4 (349)	—	—	—	—	23 3/8 (594)	—	1240 (563)	1300 (591)	—
12 (305)	—	26 1/2 (673)	28 (711)	28 (711)	—	33 (838)	15 7/8 (403)	—	—	—	—	25 1/4 (641)	—	2060 (936)	2140 (972)	—

*Add 65% to D dimension for stem removal clearance.

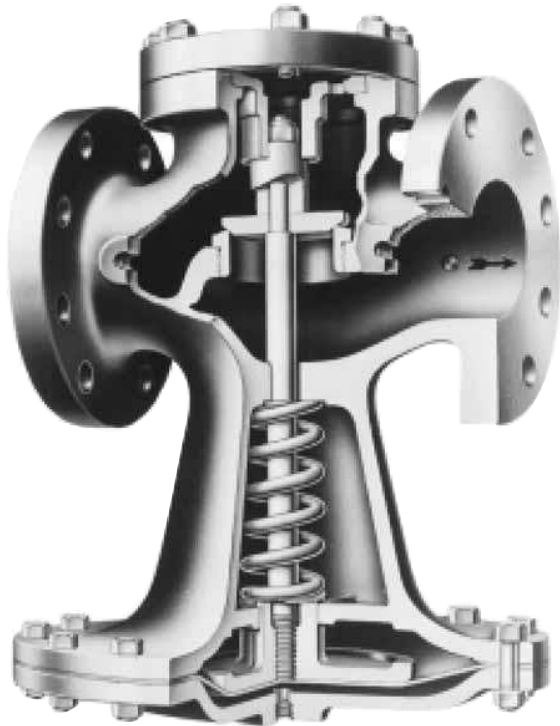

TYPE E2 MAIN VALVE

TYPE E2 MAIN VALVE

LOW PRESSURE LOW DIFFERENTIAL

SIZES 3/4" – 10"
PRESSURES to 15 PSIG at 250°F

- Normally Closed
- Single Seat
- Nitrile Diaphragm
- Protected Main Spring
- Gas & Steam Applications
- Accurate Regulation Unaffected by Service Conditions
- ANSI/FCI 70-2 Class IV Shutoff
- Virtually Frictionless for Long Service Life
- Packless Construction
- Easy In-line Maintenance
- Wide Variety of Pilots for Many Applications
- Minimum Operating ΔP 3 psi (.2 bar)
- Lifetime Warranty against Wiredrawing of Seat & Disc *

APPLICATION DATA

- Pressure Regulating for Steam Distribution
- Regulating for Process Control (Temperature or Pressure)
- Maintain Back Pressure or Differential Pressure
- For use with Self-contained, Pneumatic or Electronic Pilots
- Single Point or Multiple Use Applications
- Slow Start-up or Shutdown

VALVE RATINGS

Valve Ends ASME/ANSI	Pressure PSIG (bar)	Temperature °F (°C)
-------------------------	------------------------	------------------------

CAST IRON

B16.4 Class 250 NPT	15 (1.03)	250°F (121°C)
B16.1 Class 125 Flanged	15 (1.03)	250°F (121°C)

Canadian Registration # OC 0591.9C

Installation Tip: Add EZ Connections for ease of maintenance
SEE PAGE 40

SIZING INFO
PAGE 106

OPTIONS

- Composition Disc for liquid, air or gas service
- Insulcap Insulating Jacket
- Integral Mount Pilot
- EZ Connections

TYPICAL CONFIGURATIONS

PRESSURE REDUCINGTYPE E2D
AIR ADJUSTEDTYPE E2A SERIES
BACK PRESSURETYPE E2Q
LOAD ALLOCATINGTYPE E2FD
AIR CONTROLLEDTYPE E2AP60
ELECTRONIC SLOW STARTTYPE E2D208D
SOLENOID CONTROLLEDTYPE E2MD
SOLENOID ACTUATEDTYPE E2M
DIFFERENTIALTYPE E2N
TEMPERATURE CONTROLTYPE E2T14
TEMP. & PRESSURE CONTROLTYPE E2T134

RATED FLOW COEFFICIENTS (Cv)

SEAT FACTOR	REGULATOR SIZE													
	3/4	1	1 1/4	1 1/2	2	2 1/2	3	4	5	6	8	10	12	
Full	7.6	11.7	18.9	27.4	44	68	96	143	202	255	465	748	1118	
70%-75%	—	8.8	13.2	19.2	30.8	47.6	67.2	100	141	178	—	—	—	
45%	—	—	—	12.3	—	30.6	—	64.4	—	115	—	336	—	

* When installed according to factory specifications.

TYPE E2 MAIN VALVE

SPECIFICATION

The valve shall be self-operated, external pilot type, single seated, nitrile diaphragm actuated, normally closed design. The valve will function quickly and shut tight on dead end service. Internal parts including seats, discs and stems shall be of stainless steel. There shall be no springs in the steam flow path and no stuffing box. The valve shall be easy to maintain with all parts accessible without removal from the line.

MATERIALS OF CONSTRUCTION

Body, Cast IronASTM A126 Cl. B
 Stem303 St. Stl. ASTM A582
 Disc 3/4 - 2"420 St. Stl ASTM A743 CA-40
 Disc 2-1/2 - 10"304 St. Stl. ASTM A167/A240
 Seat420 St. Stl. ASTM A743 CA-40
 GasketNon-asbestos
 DiaphragmNitrile
 SpringSteel

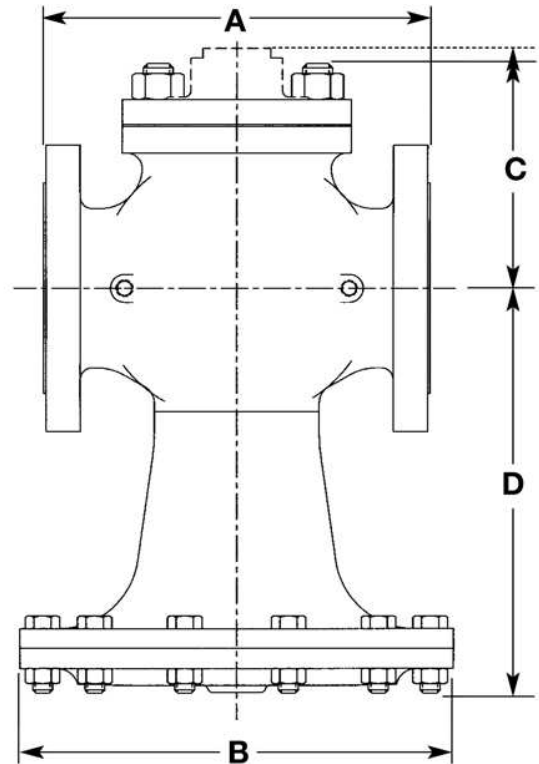

TYPE E2
MAIN VALVE

TYPE E2 MAIN VALVE

FITTINGS ON
PAGE 44

DIMENSIONS inches (mm), **WEIGHTS** pounds (kg)

SIZE	A		OTHER DIMENSIONS				APPROX. WT.	
	Cl, ANSI NPT	Cl ANSI 125	B	C		D*	Cl, ANSI NPT	Cl ANSI 125
				Std. Mount	Integral Mount			
3/4 (19)	4 3/4 (121)	—	8 (203)	2 7/8 (73)	3 5/8 (92)	7 3/4 (197)	18 (8)	—
1 (25)	5 3/8 (137)	5 1/2 (140)	8 (203)	3 5/8 (92)	4 3/8 (111)	8 1/8 (206)	19 (9)	21 (10)
1 1/4 (32)	6 1/2 (165)	6 3/4 (171)	9 (229)	4 1/8 (105)	4 (101)	8 1/4 (210)	30 (14)	33 (15)
1 1/2 (38)	7 1/4 (184)	6 7/8 (175)	9 3/4 (248)	4 3/8 (111)	4 1/2 (118)	8 3/4 (222)	36 (16)	40 (18)
2 (51)	7 1/2 (191)	8 1/2 (216)	10 1/2 (267)	5 1/4 (133)	5 (127)	10 (254)	50 (23)	57 (26)
2 1/2 (64)	—	9 3/8 (238)	10 1/2 (267)	5 3/4 (146)	5 5/8 (136)	11 1/2 (292)	—	70 (32)
3 (76)	—	10 (254)	11 1/4 (286)	6 5/8 (168)	6 5/8 (162)	12 3/4 (324)	—	98 (45)
4 (102)	—	11 7/8 (302)	13 1/2 (343)	6 3/4 (171)	6 5/8 (168)	13 5/8 (346)	—	135 (61)
5 (127)	—	13 5/8 (346)	14 1/4 (362)	7 1/2 (191)	7 3/8 (187)	15 (381)	—	185 (84)
6 (152)	—	15 1/8 (384)	16 (406)	7 7/8 (200)	7 (178)	16 5/8 (422)	—	250 (114)
8 (203)	—	19 (483)	20 (508)	9 1/2 (241)	9 1/4 (235)	19 7/8 (505)	—	1210 (550)
10 (254)	—	23 5/8 (600)	24 (610)	10 7/8 (276)	—	23 7/8 (606)	—	690 (314)

*Add 55% to D dimension for stem removal clearance.





TYPE E5 MAIN VALVE

TYPE E5 MAIN VALVE

HIGH PRESSURE-HIGH LIFT LOW DIFFERENTIAL

SIZES 3/4" – 12"
PRESSURES to 300 PSIG at 600°F

- Normally Closed
- Single Seat
- Balanced Nitrile Diaphragm
- Protected Main Spring
- Long Main Spring Operates on 5 psi Minimum Differential
- Internal & External Condensation Chambers
- Fluid, Gas & Vapor Applications
- Accurate Regulation Unaffected by Service Conditions
- ANSI/FCI 70-2 Class IV Shutoff
- Virtually Frictionless for Long Service Life
- Packless Construction
- Easy In-line Maintenance
- Wide Variety of Pilots for Many Applications
- Lifetime Warranty against Wiredrawing of Seat & Disc *

APPLICATION DATA

- Pressure Regulating for Steam Distribution
- High Pressure/Low Differential Pressure Regulating
- Fluid Regulation
- For use with Self-contained, Pneumatic or Electronic Pilots
- Slow Start-up or Shutdown

SIZING INFO
PAGE 106

VALVE RATINGS

Valve Ends ASME/ANSI	Pressure PSIG (bar)	Temperature °F (°C)
-------------------------	------------------------	------------------------

CAST IRON

Class 250 NPT	250 (17.2) @	450 (232)
B16.1 Class 125 Flanged	125 (8.6) @	450 (232)
B16.1 Class 250 Flanged	250 (17.2) @	450 (232)

CAST STEEL

B16.34 Class 300 NPT	300 (21.0) @	600 (315)
B16.34 Class 150 Flanged	150 (10.3) @	500 (260)
B16.34 Class 300 Flanged	300 (21.0) @	600 (315)

Other pressure/temperature ratings available; consult factory.
Maximum downstream pressure is 300 psi.

Canadian Registration # OC 0591.9C

Installation Tip: Add EZ Connections for ease of maintenance
SEE PAGE 40

OPTIONS

- Composition Disc for liquid, air or gas service
- Balanced Construction
- Integral Mount Pilot
- Secoweld
- EZ Connections

TYPICAL CONFIGURATIONS

PRESSURE REDUCINGTYPE E5D
AIR ADJUSTEDTYPE E5A
BACK PRESSURETYPE E5Q
PUMP GOVERNORTYPE E5P
LOAD ALLOCATINGTYPE E5FD
AIR CONTROLLEDTYPE E5AP60
ELECTRONIC SLOW STARTTYPE E5D208D
SOLENOID CONTROLLEDTYPE E5MD
SOLENOID ACTUATEDTYPE E5M
DIFFERENTIALTYPE E5N
TEMPERATURE CONTROLTYPE E5T

RATED FLOW COEFFICIENTS (Cv)

SEAT FACTOR	REGULATOR SIZE												
	3/4	1	1 1/4	1 1/2	2	2 1/2	3	4	5	6	8	10	12
Full	7.6	11.7	18.9	27.4	43	67	95	159	258	350	665	1018	1611
Normal	5.7	10.0	13.4	19.8	25	35	59	120	176	228	366	525	952

* When installed according to factory specifications.

TYPE E5 MAIN VALVE

SPECIFICATION

The valve shall be self-operated, external pilot type, single seated, diaphragm actuated, normally closed design. The valve will function quickly and shut tight on dead end service. Internal parts including seats, discs and stems shall be of stainless steel. The diaphragm shall be a balanced Nitrile material for high lift. There shall be an external condensation chamber supplied. The main valve spring shall operate on a 5 psi minimum differential. There shall be no springs in the steam flow path and no stuffing box. The valve shall be easy to maintain with all parts accessible without removal from the line.

MATERIALS OF CONSTRUCTION

Body, Cast IronASTM A126 Cl. B
 Body, Cast SteelASTM A216 WCB
 Stem303 St. Stl. ASTM A582
 Disc 3/4 - 5"420 St. Stl. ASTM A582 Cond A
 Disc 6 - 12"304 St. Stl. ASTM A167/A240
 Seat 3/4 - 5"420 St. Stl. ASTM A582 Cond A
 Seat 6 - 12"316 St. Stl. ASTM A743 CF-8M
 GasketNon-asbestos
 DiaphragmNitrile
 SpringSteel

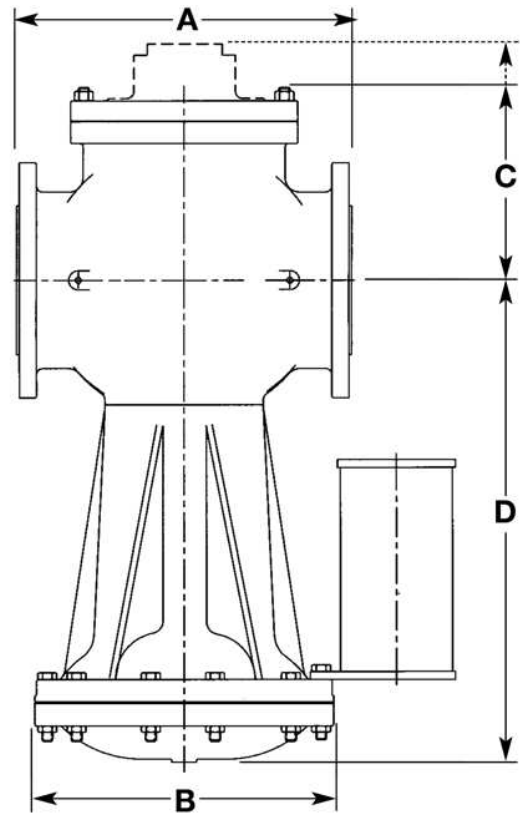

TYPE E5 MAIN VALVE

TYPE E5 MAIN VALVE

FITTINGS ON PAGE 44

DIMENSIONS inches (mm) AND WEIGHTS pounds (kg)

SIZE	A			B	C				D*		APPROX. WT				
	ANSI NPT	ANSI 125	ANSI 250		Std. Mount	Integral Mount		ANSI 125	SCR 250	Iron, Brz. Stl. ANSI NPT	Iron		Steel		
						Cl	Stl.				ANSI 125	ANSI 250	ANSI 150	ANSI 300	
3/4 (19)	4 3/4 (111)	—	—	6 7/8 (175)	2 7/8 (73)	3 3/8 (92)	3 1/2 (89)	11 1/4 (286)	11 1/4 (286)	23 (10)	—	—	—	—	
1 (25)	5 3/8 (137)	5 1/2 (140)	6 (152)	6 7/8 (175)	3 3/8 (92)	4 3/8 (111)	4 3/8 (111)	11 5/8 (295)	11 5/8 (295)	24 (11)	30 (14)	33 (15)	35 (16)	39 (18)	
1 1/4 (32)	6 1/2 (165)	6 3/4 (171)	7 1/4 (184)	9 1/8 (232)	4 1/8 (105)	4 (102)	4 5/8 (117)	13 1/2 (343)	13 1/2 (343)	49 (22)	46 (21)	49 (22)	58 (26)	63 (29)	
1 1/2 (38)	7 1/4 (184)	6 7/8 (175)	7 3/8 (187)	9 1/8 (232)	4 3/8 (111)	4 1/2 (114)	5 (127)	13 3/8 (346)	13 3/8 (346)	53 (24)	58 (26)	68 (31)	67 (30)	74 (34)	
2 (51)	7 1/2 (191)	8 1/2 (216)	9 (229)	11 1/8 (283)	5 1/4 (133)	5 (127)	5 5/8 (143)	16 1/4 (413)	16 1/4 (413)	84 (38)	90 (41)	97 (44)	113 (51)	120 (55)	
2 1/2 (64)	—	9 3/8 (238)	10 (254)	11 1/8 (283)	5 3/4 (146)	5 3/8 (137)	6 (152)	16 1/2 (419)	16 1/2 (419)	—	97 (44)	112 (51)	130 (59)	135 (61)	
3 (76)	—	10 (254)	10 3/4 (273)	13 1/2 (343)	6 5/8 (168)	6 3/8 (162)	7 (178)	19 1/4 (489)	19 1/4 (489)	—	148 (67)	170 (77)	210 (95)	226 (103)	
4 (102)	—	11 7/8 (302)	12 1/2 (318)	13 1/2 (343)	7 5/8 (194)	6 5/8 (168)	8 (203)	18 3/8 (467)	23 3/8 (594)	—	208 (95)	293 (133)	307 (139)	330 (150)	
5 (127)	—	13 3/8 (346)	14 1/2 (368)	13 1/2 (343)	8 1/2 (216)	7 3/8 (187)	8 3/4 (222)	18 3/4 (476)	23 3/4 (603)	—	240 (109)	333 (151)	335 (152)	366 (166)	
6 (152)	—	15 1/8 (384)	16 (406)	16 3/4 (425)	10 (254)	7 (178)	—	23 1/2 (597)	27 3/8 (695)	—	348 (158)	616 (280)	560 (254)	503 (274)	
8 (203)	—	19 (483)	20 (508)	16 3/4 (425)	11 1/2 (292)	9 1/4 (235)	—	23 3/4 (603)	29 3/8 (752)	—	650 (295)	814 (370)	795 (361)	862 (392)	
10 (254)	—	23 3/8 (600)	25 (635)	20 (508)	13 3/4 (349)	—	—	30 3/4 (781)	35 3/8 (899)	—	910 (414)	1130 (513)	1345 (611)	1420 (645)	
12 (305)	—	26 1/2 (673)	28 (711)	24 3/4 (629)	15 7/8 (403)	—	—	39 3/4 (1010)	39 3/4 (1010)	—	1580 (718)	1920 (872)	1990 (904)	2160 (982)	





TYPE E6 MAIN VALVE

APPLICATION DATA

- Pressure Regulating for Compressed Air Distribution
- Pressure Regulating for Gas Service
- Maintain Back Pressure or Differential Pressure
- For use with Self-contained, Pneumatic or Electronic Pilots
- Single Point or Multiple Use Applications
- Slow Start-up or Shutdown

VALVE RATINGS

Valve Ends ASME/ANSI	Pressure PSIG (bar)	Temperature °F (°C)
-------------------------	------------------------	------------------------

CAST IRON

B16.4 Class 250 NPT	250 (17.2) @	200 (93)
B16.1 Class 125 Flanged	125 (8.6) @	200 (93)

Other pressure/temperature ratings available; consult factory.

Canadian Registration # OC 0591.9C

Installation Tip: Add EZ Connections for ease of maintenance
SEE PAGE 40

SIZING INFO
PAGE 106

TYPE E6 MAIN VALVE

HIGH PRESSURE-HIGH LIFT COLD SERVICE

SIZES 3/4" – 12"
PRESSURES to 250 PSIG at 200°F

- Normally Closed
- Single Seat
- Balanced Nitrile Diaphragm
- Protected Main Spring
- Composition Disc for Tight Shutoff
- Air & Gas Applications
- Accurate Regulation Unaffected by Service Conditions
- ANSI/FCI 70-2 Class VI Shutoff
- Virtually Frictionless for Long Service Life
- Packless Construction
- Easy In-line Maintenance
- Wide Variety of Pilots for Many Applications

OPTIONS

- Dashpot for Water Service
- Insulcap Insulating Jacket
- EZ Connections
- Integral Mount Pilot
- Balanced Construction

TYPICAL CONFIGURATIONS

- PRESSURE REDUCINGTYPE E6D
- AIR ADJUSTEDTYPE E6A
- BACK PRESSURETYPE E6Q
- PUMP GOVERNORTYPE E6P
- LOAD ALLOCATINGTYPE E6FD
- AIR CONTROLLEDTYPE E6AP60
- ELECTRONIC SLOW STARTTYPE E6D208D
- SOLENOID CONTROLLEDTYPE E6MD
- SOLENOID ACTUATEDTYPE E6M
- DIFFERENTIAL.....TYPE E6N
- TEMPERATURE CONTROLTYPE E6T

RATED FLOW COEFFICIENTS (Cv)

SEAT FACTOR	REGULATOR SIZE												
	3/4	1	1 1/4	1 1/2	2	2 1/2	3	4	5	6	8	10	12
Full	7.6	11.7	18.9	27.4	43	67	95	159	258	350	665	1018	1611
Normal	5.7	10.0	13.4	19.8	25	35	59	120	176	228	366	525	952

TYPE E6 MAIN VALVE

SPECIFICATION

The valve shall be self-operated, external pilot type, single seated, composition disc, nitrile diaphragm actuated, normally closed design. The valve will function quickly and shut tight on dead end service. Seats and stems shall be of stainless steel. There shall be no springs in the flow space and no stuffing box. The valve shall be easy to maintain with all parts accessible without removal from the line.

MATERIALS OF CONSTRUCTION

Body, Cast IronASTM A126 Cl. B
 Stem303 St. Stl. ASTM A582
 DiscNitrile Comp.
 Seat 3/4 - 5"420 St. Stl. ASTM 473 CA-40
 Seat 6 - 8"316 St. Stl. ASTM A743 CF-8M
 GasketNon-asbestos
 DiaphragmNitrile
 SpringSteel
 Disc HolderASTM B16 UNS C36000

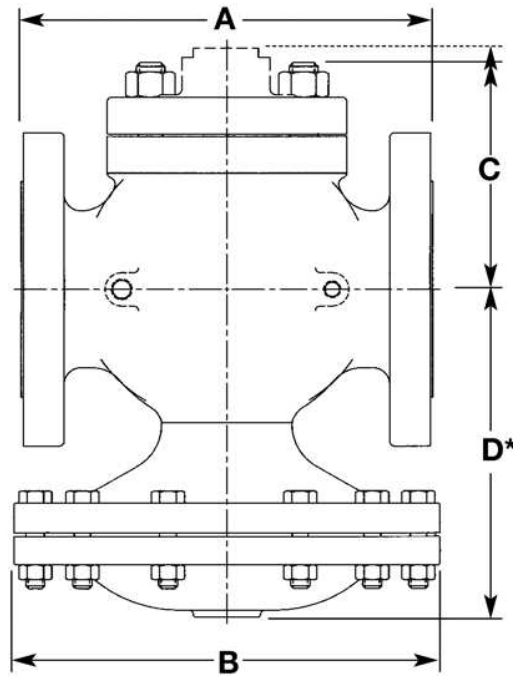

TYPE E6
MAIN VALVE

TYPE E6 MAIN VALVE

FITTINGS ON
PAGE 44

DIMENSIONS inches (mm) AND WEIGHTS pounds (kg)

SIZE	DIMENSIONS							APPROX. WT.		
	A			B	C		D*	ANSI NPT	ANSI 125	ANSI 250
	ANSI NPT	ANSI 125	ANSI 250		Std. Mount	Integral Mount				
3/4 (19)	4 3/4 (111)	—	—	6 7/8 (175)	2 7/8 (73)	3 5/8 (92)	6 3/8 (162)	18 (8)	—	—
1 (25)	5 3/8 (137)	5 1/2 (140)	6 (152)	6 7/8 (175)	3 5/8 (92)	4 3/8 (111)	6 5/8 (168)	18 (8)	27 (129)	30 (14)
1 1/4 (32)	6 1/2 (165)	6 3/4 (171)	7 1/4 (184)	9 1/8 (232)	4 1/8 (105)	4 (102)	7 3/4 (197)	37 (17)	39 (18)	44 (20)
1 1/2 (38)	7 1/4 (184)	6 7/8 (175)	7 3/8 (187)	9 1/8 (232)	4 3/8 (111)	4 1/2 (114)	7 7/8 (200)	42 (19)	50 (23)	56 (25)
2 (51)	7 1/2 (191)	8 1/2 (216)	9 (229)	11 1/8 (283)	5 1/4 (133)	5 (127)	8 5/8 (219)	66 (30)	73 (33)	81 (37)
2 1/2 (64)	—	9 5/8 (238)	10 (254)	11 1/8 (283)	5 3/4 (146)	5 5/8 (137)	9 (229)	—	83 (38)	95 (43)
3 (76)	—	10 (254)	10 3/4 (273)	13 1/2 (343)	6 5/8 (168)	6 3/8 (162)	9 7/8 (251)	—	124 (56)	146 (66)
4 (102)	—	11 7/8 (302)	12 1/2 (318)	13 1/2 (343)	7 5/8 (194)	6 5/8 (168)	12 3/4 (324)	—	206 (94)	234 (106)
5 (127)	—	13 5/8 (346)	14 1/2 (368)	13 1/2 (343)	8 1/2 (216)	7 3/8 (187)	13 1/4 (337)	—	275 (125)	287 (130)
6 (152)	—	15 1/8 (384)	16 (406)	16 3/4 (425)	10 (254)	7 (178)	15 1/2 (394)	—	363 (165)	431 (196)
8 (203)	—	19 (483)	20 (508)	16 3/4 (425)	11 1/2 (292)	9 1/4 (235)	17 5/8 (448)	—	508 (231)	610 (277)

*Add 100% to D dimension for stem removal clearance.



TYPE E8 MAIN VALVE

AIR LOADED

SIZES 3/8" – 12"

PRESSURES to 250 PSIG at 406°F

- Normally Closed
- Single Seat
- Balanced Metal Diaphragms
- ANSI/FCI 70-2 Class IV Shutoff
- No Minimum Operating Differential Pressure
- Packless Construction
- No Pilot Needed
- Maximum 50 PSI Air Delivery Pressure
- Permits Remote Operation and Control
- Economical Alternative to Control Valve

TYPE E8 MAIN VALVE

APPLICATION DATA

- Pressure Regulating for Steam Distribution
- Regulating for Process Control (Temperature or Pressure)
- Maintain Back Pressure or Differential Pressure
- To use Air Load Pressure to Control Delivery Pressure
- Single Point or Multiple Use Applications
- Slow Start-up or Shutdown
- Use where "Dirty Steam" Conditions Exist

VALVE RATINGS

Valve Ends ASME/ANSI	Pressure PSIG (bar)	Temperature °F (°C)
-------------------------	------------------------	------------------------

CAST IRON

Class 250 NPT	250 (17.2)	@ 450 (232)
B16.1 Class 125 Flanged	125 (8.6)	@ 450 (232)
B16.1 Class 250 Flanged	250 (17.2)	@ 450 (232)

Canadian Registration # OC 0591.9C

OPTIONS

- Composition Disc
- Parabolic Disc
- Balanced Construction
- Dashpot
- Insulcap Insulating Jacket
- EZ Connections

TYPICAL CONFIGURATIONS

- PRESSURE REDUCINGTYPE E8 65A
- PRESSURE REDUCINGTYPE E8 A PANEL
- PRESSURE REDUCINGTYPE E8 B PANEL
- PRESSURE REDUCINGTYPE E8EPC
- TEMPERATURE CONTROLTYPE E8T61
- TEMPERATURE CONTROLTYPE E8EPC

Installation Tip: Add EZ Connections for ease of maintenance
SEE PAGE 40

SIZING INFO
PAGE 106

RATED FLOW COEFFICIENTS (Cv)

SEAT FACTOR	REGULATOR SIZE														
	3/8	1/2	3/4	1	1 1/4	1 1/2	2	2 1/2	3	4	5	6	8	10	12
Full	1.5	2.8	5.4	8.8	14.1	19.8	31	44	74	109	169	248	444	706	1113
Full 75 %	—	2.2	4.2	7.2	11.1	15.9	22.9	37	56	88	136	188	353	558	880
Full 50 %	—	1.7	2.6	6.3	7.4	11.3	17.7	25	42	65	94	139	252	400	631
Normal	.66	1.55	4.8	7.5	10.4	14.6	17.6	24	43	78	115	151	249	377	631
Normal 75 %	—	—	—	—	—	—	—	18	34	62	89	110	187	294	463
Normal 50 %	—	—	—	—	—	—	—	14	26	46	65	83	139	230	363

TYPE E8 MAIN VALVE

SPECIFICATION

The valve shall be air operated, single seated, metal diaphragm actuated, normally closed design. The valve will function quickly and shut tight on dead end service. Internal parts including seats, discs, stems and diaphragms shall be of stainless steel. There shall be no springs in the steam space and no stuffing box. The valve shall be easy to maintain with all parts accessible without removal from the line.

MATERIALS OF CONSTRUCTION

Body, Cast IronASTM A126 Cl. B
 Stem303 St. Stl. ASTM A582
 Disc 3/4 - 5"420 St. Stl. ASTM A743 CA-40
 Disc 6 - 12"304 St. Stl. ASTM A167/A240
 Seat 3/4 - 5"420 St. Stl. ASTM A743 CA-40
 Seat 6 - 12"316 St. Stl. ASTM A743-79 CF-8M
 GasketNon-asbestos
 DiaphragmStainless Steel MIL-S-5059C
 SpringSteel

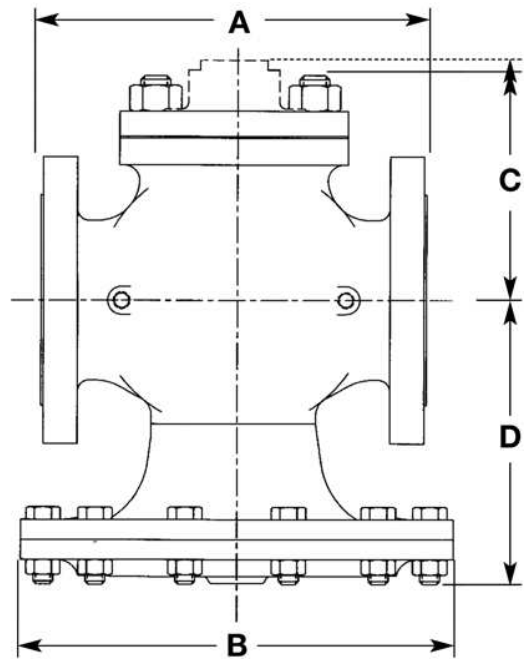

TYPE E8
MAIN VALVE

TYPE E MAIN VALVE

FITTINGS ON
PAGE 44

DIMENSIONS inches (mm) AND WEIGHTS pounds (kg)

SIZE	FACE TO FACE DIMENSIONS					OTHER DIMENSIONS					APPROX. WT.					
	A					B	C		D	E	APPROX. WT.					
	ANSI NPT	ANSI 125,150	ANSI 250	ANSI 300	ANSI 600			ANSI 600			ANSI NPT	ANSI 125	ANSI 150	ANSI 250	ANSI 300	ANSI 600
3/8 (10)	4 3/8 (111)	—	—	—	—	5 7/8 (149)	2 3/4 (70)	—	5 1/4 (133)	7 3/8 (187)	14 (31)	—	—	—	—	—
1/2 (12)	4 3/8 (111)	—	—	—	6 (152)	5 7/8 (149)	2 3/4 (70)	2 3/4 (70)	5 1/4 (133)	7 3/8 (187)	14 (31)	—	—	—	—	20 (44)
3/4 (19)	4 3/8 (111)	—	—	—	6 3/8 (162)	6 1/2 (165)	2 7/8 (73)	3 3/8 (98)	5 1/2 (140)	7 7/8 (200)	18 (40)	—	—	—	—	28 (62)
1 (25)	5 3/8 (137)	5 1/2 (140)	6 (152)	6 1/2 (165)	6 1/2 (165)	7 (178)	3 5/8 (92)	4 1/4 (108)	6 1/4 (159)	8 7/8 (225)	23 (51)	24 (53)	26 (57)	27 (59)	31 (68)	32 (70)
1 1/4 (32)	6 1/2 (165)	6 3/4 (171)	7 1/4 (184)	7 7/8 (200)	7 7/8 (200)	7 7/8 (200)	4 1/8 (105)	4 5/8 (117)	6 1/2 (165)	9 1/8 (232)	33 (73)	36 (79)	37 (81)	40 (88)	41 (90)	45 (99)
1 1/2 (38)	7 1/4 (184)	6 7/8 (175)	7 3/8 (187)	8 (203)	8 (203)	8 3/4 (222)	4 3/8 (111)	5 1/8 (130)	7 1/8 (181)	9 3/4 (248)	43 (95)	45 (99)	47 (103)	51 (112)	55 (121)	58 (128)
2 (51)	7 1/2 (191)	8 1/2 (216)	9 (229)	10 1/4 (260)	10 1/4 (260)	9 7/8 (251)	5 1/4 (133)	5 3/4 (146)	7 5/8 (194)	11 1/4 (286)	62 (136)	67 (147)	73 (161)	72 (158)	78 (172)	83 (183)
2 1/2 (64)	—	9 3/8 (238)	10 (254)	11 1/4 (286)	11 1/4 (286)	10 7/8 (276)	5 3/4 (146)	7 7/8 (200)	8 3/8 (213)	12 1/8 (308)	—	82 (180)	95 (209)	100 (220)	100 (220)	130 (286)
3 (76)	—	10 (254)	10 3/4 (273)	12 1/4 (311)	12 1/4 (311)	11 3/4 (298)	6 5/8 (168)	9 1/8 (232)	9 1/4 (235)	14 5/8 (371)	—	110 (242)	125 (275)	130 (286)	140 (308)	175 (385)
4 (102)	—	11 7/8 (302)	12 1/2 (318)	12 1/2 (318)	14 1/2 (368)	14 3/4 (375)	7 5/8 (194)	10 5/8 (270)	11 7/8 (302)	18 1/4 (464)	—	200 (440)	210 (462)	235 (517)	230 (506)	310 (682)
5 (127)	—	13 5/8 (346)	14 1/2 (368)	14 1/2 (368)	16 1/2 (419)	16 7/8 (429)	8 1/2 (216)	12 1/2 (318)	12 1/2 (318)	20 1/8 (511)	—	280 (616)	295 (649)	315 (693)	310 (682)	490 (1078)
6 (152)	—	15 1/8 (384)	16 (406)	16 (406)	17 3/8 (441)	19 3/4 (502)	10 (254)	13 3/4 (349)	14 1/8 (359)	22 3/8 (568)	—	385 (847)	420 (924)	455 (1001)	470 (1034)	655 (1441)
8 (203)	—	19 (483)	20 (508)	20 (508)	21 5/8 (549)	22 1/2 (572)	11 1/2 (292)	15 3/8 (391)	17 1/4 (438)	27 3/4 (705)	—	657 (1445)	700 (1540)	735 (1617)	710 (1562)	1070 (2354)
10 (254)	—	23 5/8 (600)	25 (635)	25 (635)	—	28 (711)	13 3/4 (349)	—	23 3/8 (594)	36 1/4 (921)	—	1260 (2772)	1240 (2728)	1430 (3146)	1300 (2860)	—
12 (305)	—	26 1/2 (673)	28 (711)	28 (711)	—	33 (838)	15 7/8 (403)	—	25 1/4 (641)	41 1/2 (1054)	—	2070 (4554)	2060 (4532)	2145 (4719)	2140 (4708)	—



TYPE C34 MAIN VALVE

APPLICATION DATA

- Pressure Regulating for Liquid Distribution
- Regulating for Process Control (Temperature or Pressure)
- Maintain Back Pressure or Differential Pressure
- For use with Self-contained, Pneumatic or Electronic Pilots
- Single Point or Multiple Use Applications
- Slow Start-up or Shutdown

VALVE RATINGS

Valve Ends ASME/ANSI	Pressure PSIG (bar)	Temperature °F (°C)
-------------------------	------------------------	------------------------

CAST IRON

B16.4 Class 250 NPT	250 (13.8) @	200 (93)
B16.1 Class 125 Flanged	125 (11.4) @	200 (93)
B16.1 Class 250 Flanged	250 (13.8) @	200 (93)

Canadian Registration # OC 0591.9C

Installation Tip: Add EZ Connections for ease of maintenance
SEE PAGE 40

SIZING INFO
PAGE 106

TYPE C34 MAIN VALVE

BALANCED SINGLE SEAT LIQUID SERVICE

SIZES 1" – 6"
PRESSURES to 250 PSIG at 200°F

- Normally Closed
- Single Seat
- Nitrile Diaphragm
- Balanced Composition Disc
- Protected Main Spring
- Balanced Piston Design without Dashpot
- Fluid Applications
- Accurate Regulation for Non-violent Load Fluctuations
- ANSI/FCI 70-2 Class VI Shutoff
- Virtually Frictionless for Long Service Life
- Packless Construction
- Wide Variety of Pilots for Many Applications

OPTIONS

- EZ Connections

TYPICAL CONFIGURATIONS

- PRESSURE REDUCINGTYPE C34D
- AIR ADJUSTEDTYPE C34A
- BACK PRESSURETYPE C34Q
- PUMP GOVERNORTYPE C34P
- LOAD ALLOCATINGTYPE C34FD
- AIR CONTROLLEDTYPE C34AP60
- ELECTRONIC SLOW STARTTYPE C34D208D
- SOLENOID CONTROLLEDTYPE C34MD
- SOLENOID ACTUATEDTYPE C34M
- DIFFERENTIALTYPE C34N
- COOLING CONTROLTYPE C34T

RATED FLOW COEFFICIENTS (Cv)

REGULATOR SIZE								
1	1¼	1½	2	2½	3	4	5	6
5.5	12.5	17.3	24	36	53	86	139	196

TYPE C34 MAIN VALVE

SPECIFICATION

The valve shall be self-operated, external pilot type, single seated, diaphragm actuated, normally closed design. The valve will shut tight on dead end service and shall maintain a discharge pressure which will not vary more than 10% (2 psi minimum) of set point from zero flow to rated flow regardless of inlet pressure variation. Valve shall be suitable for 200°F (93°C) service temperature. Bodies shall be cast iron. Sizes 2-1/2" and larger shall have flanged ends. Trim shall be stainless steel. Valves shall be equipped with a reversible composition disc. Diaphragms and discs shall be nitrile. There shall be no springs in the fluid space and no stuffing box.

MATERIALS OF CONSTRUCTION

Body, Cast IronASTM A126 Cl. B
 Stem303 St. St. ASTM A582
 DiscNitrile Comp
 Seat 1 - 2"303 St. St. ASTM A582
 Seat 2 1/2 - 6"304 St. St. ASTM A276 Cond A
 GasketNon-asbestos
 DiaphragmNitrile
 SpringSteel

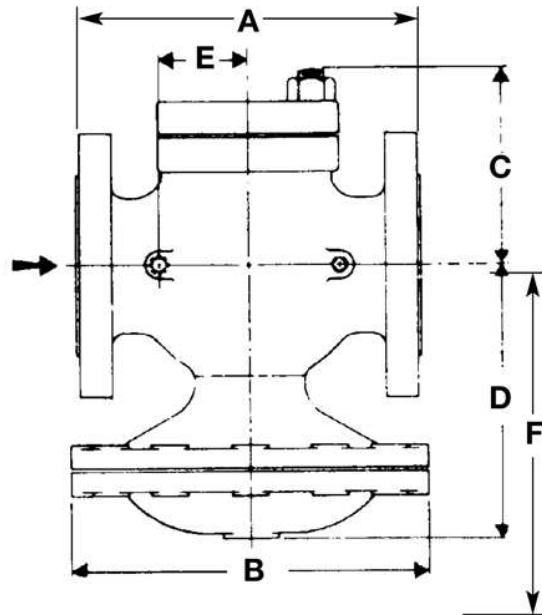

TYPE C34 MAIN VALVE

FITTINGS ON
PAGE 44

TYPE C34
MAIN VALVE

DIMENSIONS inches (mm) AND WEIGHTS pounds (kg)

SIZE	FACE TO FACE			OTHER DIMENSIONS						APPROX. WT.		
	A			B	C	D	E	F	G	ANSI NPT	ANSI 125	ANSI 250
	ANSI NPT	ANSI 125	ANSI 250									
1 (25)	5 3/8 (137)	—	—	6 7/8 (175)	3 3/8 (86)	7 (178)	1 3/8 (35)	6 (152)	10 3/8 (264)	19 (9)	—	—
1 1/4 (32)	6 1/2 (165)	—	—	6 7/8 (175)	3 7/8 (98)	7 (178)	1 13/16 (46)	6 5/8 (168)	11 1/4 (286)	24 (11)	—	—
1 1/2 (38)	7 1/4 (184)	—	—	6 7/8 (175)	4 1/4 (108)	7 (178)	1 15/16 (49)	6 3/8 (162)	11 7/8 (302)	29 (13)	—	—
2 (51)	7 1/2 (191)	8 1/2 (216)	9 (229)	9 1/8 (232)	4 1/2 (114)	7 (178)	2 1/16 (52)	6 1/2 (165)	12 1/2 (318)	46 (21)	51 (13)	60 (27)
2 1/2 (64)	—	9 3/8 (238)	10 (254)	9 1/8 (232)	5 1/2 (140)	7 3/8 (187)	2 3/8 (60)	6 7/8 (175)	14 1/2 (368)	—	65 (30)	74 (34)
3 (76)	—	10 (254)	10 3/4 (273)	11 1/8 (283)	6 (152)	8 3/4 (222)	2 3/4 (70)	7 1/4 (184)	15 7/8 (403)	—	94 (43)	111 (50)
4 (102)	—	11 7/8 (302)	12 1/2 (318)	13 1/2 (343)	6 5/8 (168)	9 3/8 (238)	3 (76)	7 3/4 (197)	17 3/4 (451)	—	148 (67)	172 (78)
5 (127)	—	13 5/8 (346)	14 1/2 (368)	13 1/2 (343)	7 5/8 (194)	10 7/8 (276)	3 1/2 (89)	8 5/8 (219)	20 1/4 (514)	—	194 (88)	226 (103)
6 (152)	—	15 1/8 (384)	16 (406)	13 1/2 (343)	9 1/8 (232)	13 1/8 (333)	4 1/4 (108)	10 5/8 (270)	25 1/8 (638)	—	280 (127)	325 (148)

NOTES:

MAIN VALVE ACCESSORIES

MAIN VALVE OPTIONS

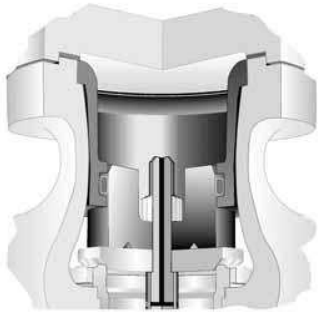

BALANCED CONSTRUCTION

There are installations where it is desirable to not have the inlet pressure forcing down on the Main Valve Disc. In these instances, the E Main Valve should be internally balanced. The balance parts allow the downstream pressure to rest on top of the disc, thus allowing for finer adjustments in the Main Valve travel and a smoother operating regulator. The balance cylinder is suitable for 550° F max temperatures.

SECOWELD

The greatest weakness in a High Pressure Valve is the threaded joint between the Seat Ring and the body. A slight leak developing at this point will gradually erode the Body metal, thus accentuating the leak and eventually ruining the body. Various impractical schemes, such as welding the Seat Ring into the Body, have been tried to overcome this weakness. The invention SECOWELD solves this problem and, at the same time, provides an easily renewable Seat Ring. In the SECOWELD Design, a SECO Metal Bushing is welded to and thus sealed in the Body and, in turn, is threaded to take the Main Seat Ring, which is also of SECO Metal. As SECO Metal resists wire drawing, if slight leakage should occur, no damage can be done to the body or to the threads of either SECO Metal piece.



EZ CONNECTIONS

Provides the performance of a flanged connection with the simplicity of a union connection. Unlike conventional unions, EZ Connections do not require matched sets or springing pipe to clear cone tolerances and do not leak after just a few disassembly/reassembly cycles. Uniform end to end dimensions simplify rough-in schematics. Available on 1/2" through 2" threaded main valves in NPT, socketweld and threaded by socketweld connections.

Consult Factory for pricing and availability.

CONDENSATION CHAMBER

A Condensation Chamber is standard on the Type E5 Main Valve. A Condensation Chamber is standard on the Type E Main Valve when steam temperatures exceed 600°F. Any Main Valve discharging steam into a vacuum should include a Condensation Chamber.

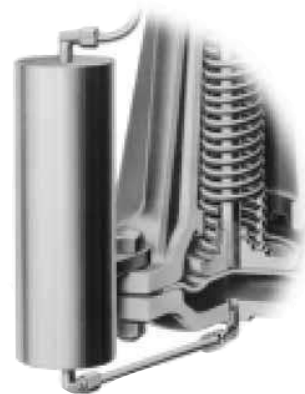

MAIN VALVE OPTIONS

LOW DIFFERENTIAL PRESSURE (LP) MAIN SPRING

The E Series Main Valves provide superior regulation in a broad range of applications by utilizing a specialized Main Spring. When differential pressures between 10-50 psi are desired, E Main Valves should be equipped with the optional LP Main Spring. The LP Main Spring alone will achieve differential pressures to 15 psi. In order to attain differential pressures to 10 psi, optional 5B Open Elbow and 1/16" 4A Bleedport are required.

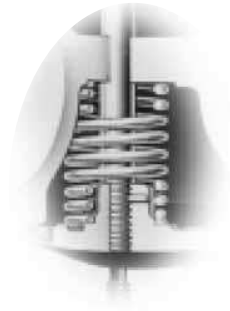

COMPOSITION DISC

In a Single Seat Main Valve, the Integral (all-metal) Disc is interchangeable with the Composition Disc Assembly. The Composition Disc is recommended for service on air, gas and water where absolutely tight shutoff is required and is available on Full and Normal seats and Parabolic valve plugs. The Composition Disc is suitable for pressures to 200 psi and temperatures to 200°F.

PARABOLIC DISC

In order to meet special flow requirements, any Spence Main Valve can be equipped with a Parabolic or other specially shaped Disc. Due to the fact that the Spence Main Valve is operated by a large, balanced Diaphragm and is nearly frictionless in operation, special Discs are not required on normal installations.

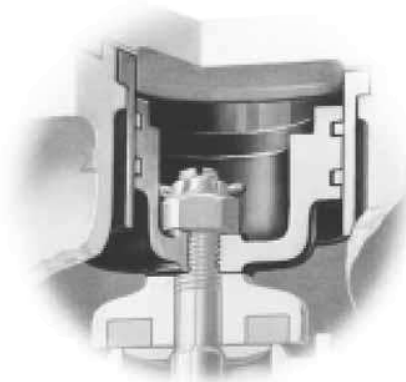
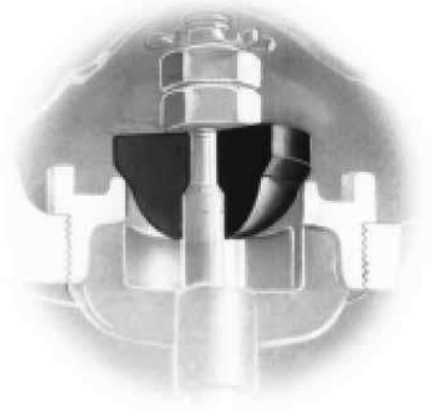

DASHPOT

In order to prevent water hammer, Dashpots are required in all single seat, normally closed Main Valves used on liquid service, except Type C34. Dashpots are neither necessary nor desirable on steam, air or gas service and are not required in double seat valves or in normally open single seat valves. Illustration shows Dashpot and Composition Disc for initial pressures of 200 psig and less. For initial pressures greater than 200 psig, standard metal to metal seat and disc are used.



INSULCAP JACKET

INSULCAP SERIES

THERMAL & ACOUSTIC BLANKET INSULATION

Temperatures to 450°F (260°C)
Average Sound Reduction of 6 dBa

- **Real Return on Investment** — 93% reduction in thermal losses over bare metal. ROI calculations available!
- **1 1/2" Thick Insulation** — Custom designs available!
- **CAD Designed and CNC Produced** — Ensures exact fit and quality coverage.
- **Thermal or Acoustic Design** — Realize up to \$1200 per year in energy savings; optional acoustic barrier provides reduction of harmful radiant noise.
- **Integral Fastener Hardware** — Flexible and easy to install, remove and reinstall.
- **Riveted Nameplate** — Ideal for large projects or sensitive industries, blankets are traceable and certifiable.

APPLICATIONS

- E Main Valves
- J, K and Boss Control Valves
- Safety Relief Valves
- P³ and Condensate Commander Pumps
- Steam Separators and Condensate Receivers
- Steam Traps
- Strainers
- Check Valves

MATERIALS OF CONSTRUCTION

Core Filler..... ASTM C 1086-88
 Jacketing Material.....PTFE Coated Fiberglass Composite
 Sound Reflector.....ASTM E 90-90

SPECIFICATION

Blanket insulation shall be 1 1/2" thick, of 16.5 oz/yd² impregnated fiberglass cloth and mat design, with double sewn lock stitched seams, 7 stitches per inch minimum. Acoustic design shall use a barium sulfate sound reflector material, and shall be rated using ASTM E1222-87. Extended fabric flaps shall be included for overlapping of pipe insulation. Nameplate shall be of permanent design, showing location, description, size,

pressure rating and sequential tag number. Fasteners shall be stainless steel, permanently affixed, and properly aligned for multiple removals and installations. Blankets shall have a stainless steel drain grommet or mating seam at lowest installed point for drainage and leak detection. Quilting pins, secured with stainless steel speed washers, shall be incorporated into the blanket at random, no greater than 18" apart.

TYPES A & B PANELS

- Gauges indicate Air Loading, Air Supply and/or Delivery Pressures
- Integral Filter Conditions Dirty Shop Air
- 50 PSI Delivery Pressure
- Accurate Delivery Pressure over Wide Range of Flow

OPTIONS

- HIGH DELIVERY PRESSURE

MODELS

- **MODEL A AIR ADJUSTMENT PANEL** includes an air adjusting valve incorporating its own bleed and two gages; one for the supply air, the other to indicate the adjusting air. It comes complete and ready to be mounted directly on a control board or box.
- **MODEL B AIR ADJUSTMENT PANEL** is the same as the Model A with the exception that it has, in addition, a gage indicating the delivery pressure.

TYPICAL CONFIGURATIONS

For use with:

- EA
- Positioners
- Any Controller Requiring Conditioned Pneumatic Signal
- E8
- EPC



TYPE B PANEL

APPLICATION DATA

- To display Air Loading, Air Supply and/or Delivery Pressure
- To Remotely Adjust Air Pilots
- To Reduce Plant Air Pressure to Instrument Air Pressure for Signaling Regulators and Control Valves
- To Filter Plant Air to Instrument Air Quality

SPECIFICATION

Air Adjustment Panel shall provide remote control for air actuated regulators and control valves. It shall convert plant air to instrument quality air and provide 0 to 50 psi delivery pressure. The Panel shall have a flow capacity of 22 scfm. Panel shall have gauges indicating air load pressure and air supply pressure with option of process delivery pressure gauge.

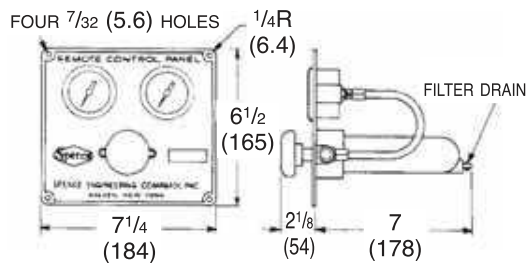

TYPE A PANEL cutout 5 1/4 (133) high by 6 (152) wide

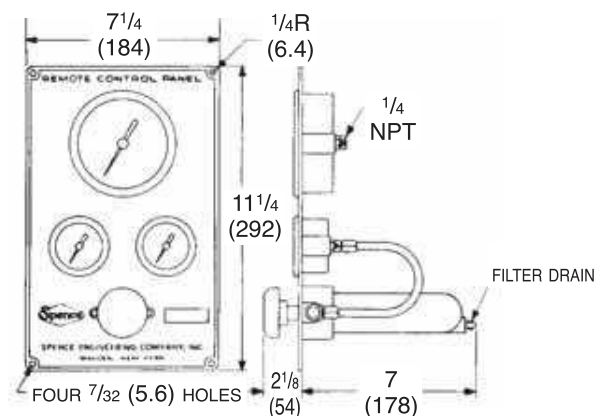

TYPE B PANEL cutout 10 1/4 (286) high by 6 (152) wide

AUXILIARY FITTINGS

BLEEDPORTS

For steam, air and gas service, a 3/32" bleedport orifice is used for main valve sizes up to 8". For 10" and 12" main valve sizes, a 1/8" bleedport orifice is used. If the initial pressure or pressure drop is less than 15 psig, the orifice is reduced to 1/16". For liquids: fuel oil utilizes a 3/32" bleedport and all other fluids utilize a 1/16" bleedport regardless of pressure conditions. For main valve sizes up to 8" on long pressure drops, the orifice is sometimes increased to 1/8" to eliminate hunting or to make the valve close faster and open slower.



4A BLEEDPORT

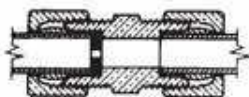

1A UNION BLEEDPORT

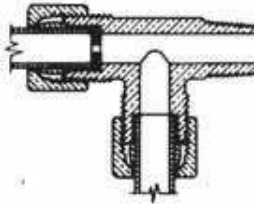

8A BLEEDPORT TEE

RESTRICTIONS

Spare restriction fittings can be supplied blank and drilled for a particular main valve according to the table. If the initial pressure or pressure drop is less than 15 psi, an open fitting is used. All back pressure valves employ an open fitting. For liquid services (except back pressure) the restriction orifice is 1/16" for all sizes of main valves.

E MAIN VALVE RESTRICTION ORIFICES*

MAIN VALVE SIZE	ORIFICE DRILL SIZE	DECIMAL EQUIVALENT
3/8	60	.0400
1/2	60	.0400
3/4	60	.0400
1	60	.0400
1 1/4	58	.0420
1 1/2	58	.0420
2	56	.0465
2 1/2	56	.0465
3	53	.0595
4	51	.0670
5	47	.0785
6	45	.0820
8	42	.0935
10	17	.1730
12	7	.2010

* Steam, Air & Gas.

If the initial pressure or pressure drop is less than 15 psi, a No. 5A elbow with orifice removed is used

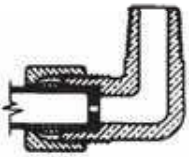

5A RESTRICTION ELBOW

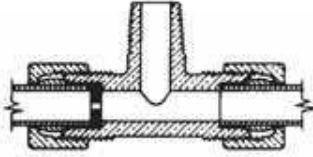

7A SAFETY PILOT RESTRICTION TEE

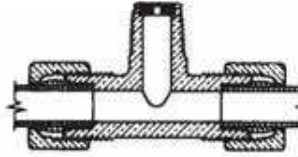

7C ANTI-FREEZE RESTRICTION TEE

OPEN FITTINGS

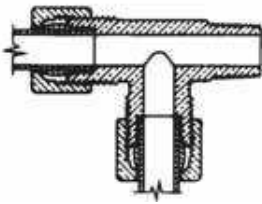

8B TEE

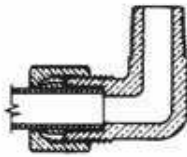

5B ELBOW

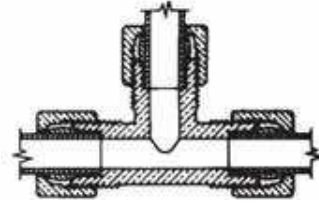

9B TUBING TEE

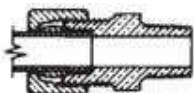

4B COUPLING

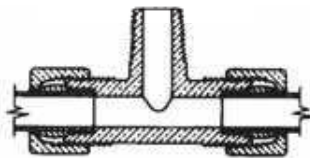

7B TEE

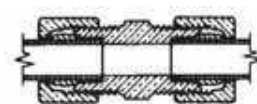

1B UNION